

透气型电缆接头

Cable Gland-Air Permeable Type

M

CE ROHS IP68 REACH

材质:	黄铜镀镍	Material:	Nickel-plated brass
芯套:	尼龙 V2 (UL94)	Plastic Claw:	Nylon V2 (UL94)
密封件:	改性橡胶	Seal:	Modified rubber
防护等级:	在规定电缆外径内并使用合适 O 形密封圈防护等级可以达到 IP68, 防水深度达到 3M-5M	Protection degree:	In the specified cable outer diameter and the appropriate o-ring Protection degree can reach IP68, the waterproof depth reaches 3M - 5M
工作温度:	-40°C~100°C, 短时间内可达到 120°C	Temperature:	-40°C-100°C, short time to 120°C
阻燃等级:	V2 (UL94), 满足 ROHS 要求	Flame retardant degree:	V2(UL94), match ROHS standard
散热透气:	2400ml/s/㎡ @0.02bar	Heat dissipation permeability:	2400ml/s/㎡ @0.02bar
进水压力:	>5bar	Water inlet pressure:	> 5bar

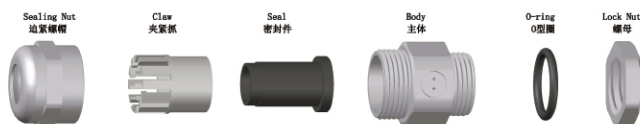
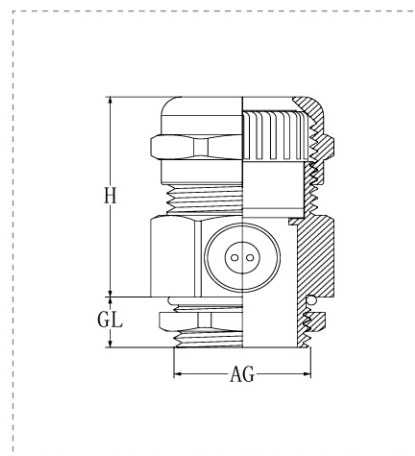

规格参数 单位: mm

规格 Item	适用范围 Range	螺纹长度 GL	螺纹外径 Thread O.D.	接合长度 H Joint Length	扳手尺寸 Spanner size	产品编号 Code
M12×1.5	3-6.5	6.5	12.0	27	16	HX-NFM12
	4-8	8	12.0	27	16/14	HX-NFM12-8
M16×1.5	3-6	8	16.0	27	18	HX-NFM16-6
	4-8	8	16.0	27	18	HX-NFM16
M18×1.5	5-10	8	16.0	27	20/18	HX-NFM16-10
	5-10	8	18.0	29	20	HX-NFM18
M20×1.5	5-10	8	20.0	32	22	HX-NFM20-10
	6-12	8	20.0	32	22	HX-NFM20
M25×1.5	10-14	8	20.0	32	24/22	HX-NFM20-12
	8-12	9	25.0	35	24/27	HX-NFM25-12
	10-14	9	25.0	35	24/27	HX-NFM25-14
	12-16	9	25.0	35	27	HX-NFM25-16
M32×1.5	13-18	9	25.0	35	30/27	HX-NFM25-18
	13-18	10	32.0	54	35	HX-NFM32-18
	15-22	10	32.0	54	35	HX-NFM32
M40×1.5	18-25	10	32.0	54	40/35	HX-NFM32-25
	18-25	11	40.0	46	40/45	HX-NFM40-25
	22-30	11	40.0	50	45	HX-NFM40-30
M50×1.5	25-33	11	40.0	52	50/45	HX-NFM40-33
	32-38	13	50.0	55	57/55	HX-NFM50
M63×1.5	37-44	14	63.0	55	64/68	HX-NFM63
	42-52	14	63.0	55	78/68	HX-NFM63-52

可选择 PG/G/NPT 螺纹定制 Customizable PG/G/NPT thread

